



---

Daruifuno

# Low Range Turbidity Sensor

## Basic User Manual



---

Model: OLTU6

Version 1.0



## Quality Assurance

Our company guarantees the sensor for one year (12 months) from the day it leaves the factory. The consumables and wearing parts in the equipment are not covered by the warranty. If the sensor damage occurs beyond the warranty period, or the company believes that the sensor is damaged or destroyed as improper use, lack of maintenance, improper installation, improper modification, abnormal environmental conditions, etc., this warranty clause will not apply. Under the provisions of this warranty, the company's obligations are limited to providing replacement or repair of this product as appropriate. The product must be thoroughly cleaned before being accepted for replacement or repair to remove any attached chemicals. The company's obligations should not exceed the price of the product itself. In any case, the company is not obligated to bear damages caused by accidents or subsequent causes, whether to persons or objects. The company is not obligated to bear any other losses, damages or other expenses, including: economic losses caused by the installation, use of this product or the unsuitability of this product.

- For details, please refer to the quality commitment letter that comes with the product, and keep this manual and the quality commitment letter that come with the product properly.



# Contents

## Part 1 Introduction

<b>Chapter 1</b>	<b>Specifications</b> .....	<b>1</b>
<b>Chapter 2</b>	<b>Basic Information</b>	
	2.1 Security Information .....	2
	2.2 Overview .....	2
	2.3 Dimensions .....	2

## Part 2 Installation

<b>Chapter 3</b>	<b>Installation</b> .....	<b>3</b>
	3.1 Sensor Installation .....	3
	3.2 Sensor Wiring .....	4

## Part 3 The use of the sensor connected to the instrument

<b>Chapter 4</b>	<b>System default setting value</b> .....	<b>5</b>
<b>Chapter 5</b>	<b>Probe set</b> .....	<b>6</b>
<b>Chapter 6</b>	<b>Menu</b> .....	<b>7</b>
	6.1 Probe CAL .....	7
	6.2 Response Time .....	8
	6.3 Wash Set .....	8
	6.4 Temperature .....	8
	6.5 Probe State .....	8

## Part 4 The use of the sensor connected to data acquisition equipment

<b>Chapter 7</b>	<b>Sensor use</b> .....	<b>9</b>
	7.1 Protocol .....	9
	7.2 Reading .....	9
	7.3 Calibration .....	9
	7.4 Reset CAL .....	10
	7.5 Temp CAL .....	10

## Part 5 Maintenance

<b>Chapter 8</b>	<b>Maintenance</b> . . . . .	<b>11</b>
	8.1 Maintenance Cycle . . . . .	11
	8.2 Cleaning . . . . .	11
	8.3 Drain . . . . .	11

## Appendix

A Instrument Modbus register information . . . . .	13
B Sensor Modbus register information . . . . .	15

# Part 1 Introduction

## Chapter 1

### Specification

If there is any change in the specifications of the product, please forgive us for no further notice

Measuring principle	Laser Scattering
Measuring range	0.001~100NTU
Accuracy	0.001~40NTU is $\pm 2\%$ of the reading or $\pm 0.015$ NTU, take the larger one; 40~100NTU is $\pm 5\%$ of the reading
Calibration method	Offset correction, factor correction, linear calibration
Working temperature	0~45°C
Storage temperature	-10~65°C
Protection grade	IP65 (indoor)
Power supply	12VDC, power consumption about 200mA
Pipe fitting interface	Inlet: 1/4" quick connector
	Outlet: 12mm Barbed connector
	Drain outlet: 12mm Barbed connector
Flow requirement	100~700mL/min
Main material	Nylon body
Dimension	140x120x320mm
Weight	About 1KG (Without cable)
Cable	Rubber sheath, standard 2 meters, length can be customized

### 2.1 Security Information

Please read this manual completely before unpacking, installing and operating this equipment. Pay special attention to all precautions. Otherwise, it may cause serious personal injury to the operator or damage the equipment.



**III Class B laser products, pay attention to laser radiation, do not look directly into the beam!**

### 2.2 Overview

The flow turbidity sensor shoots the 660nm laser vertically downwards into the water. The light is scattered by suspended particles in the water sample, and the scattered light at 90 degrees with the incident angle is received by the silicon photocell receiver immersed in the water sample, and 90 degrees is calculated. The relationship between the scattered light and the incident light beam obtains the turbidity value of the water sample.

The sensor is suitable for swimming pools, water plants, secondary water supply, surface water, water treatment and other fields, and can continuously monitor the turbidity value of aqueous solutions.

### 2.3 Dimension

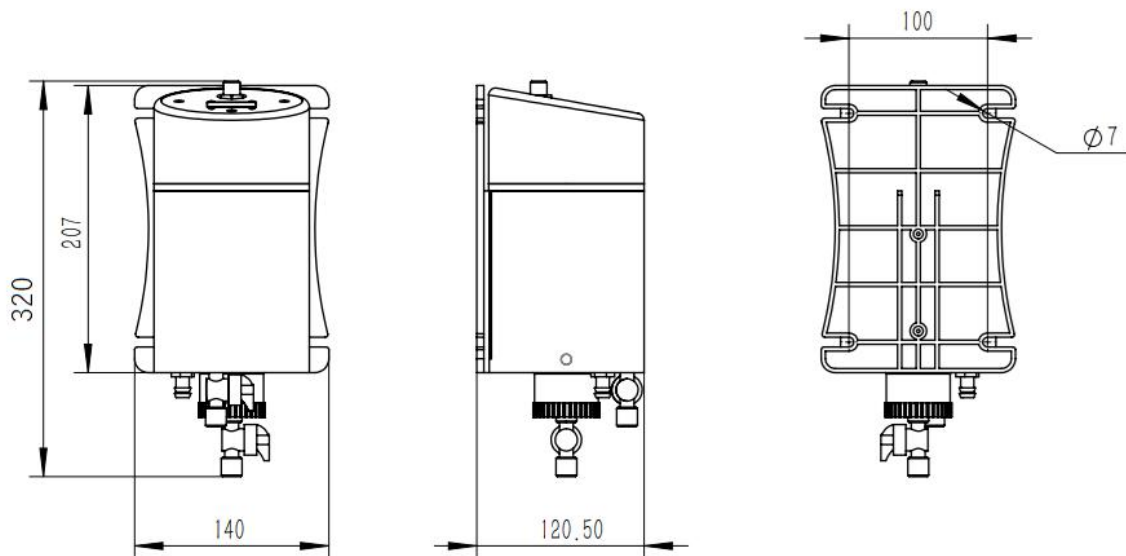

Figure 1 Dimensions of the sensor



## Part 2 Installation

### Chapter 3

#### Installation

#### 3.1 Sensor Installation

Refer to the pictures in this section to install and fix the sensor. To ensure that the sensor can measure safely and accurately, the following conditions must be met during installation:

- The sensor installation position should be as close as possible to the sampling point;
- The sensor should be installed in a location where there is no vibration;
- Leave at least 260mm space above the sensor for removing the upper cover of the sensor;
- There should be enough space under the sensor to put a container at the drain port during calibration or cleaning.

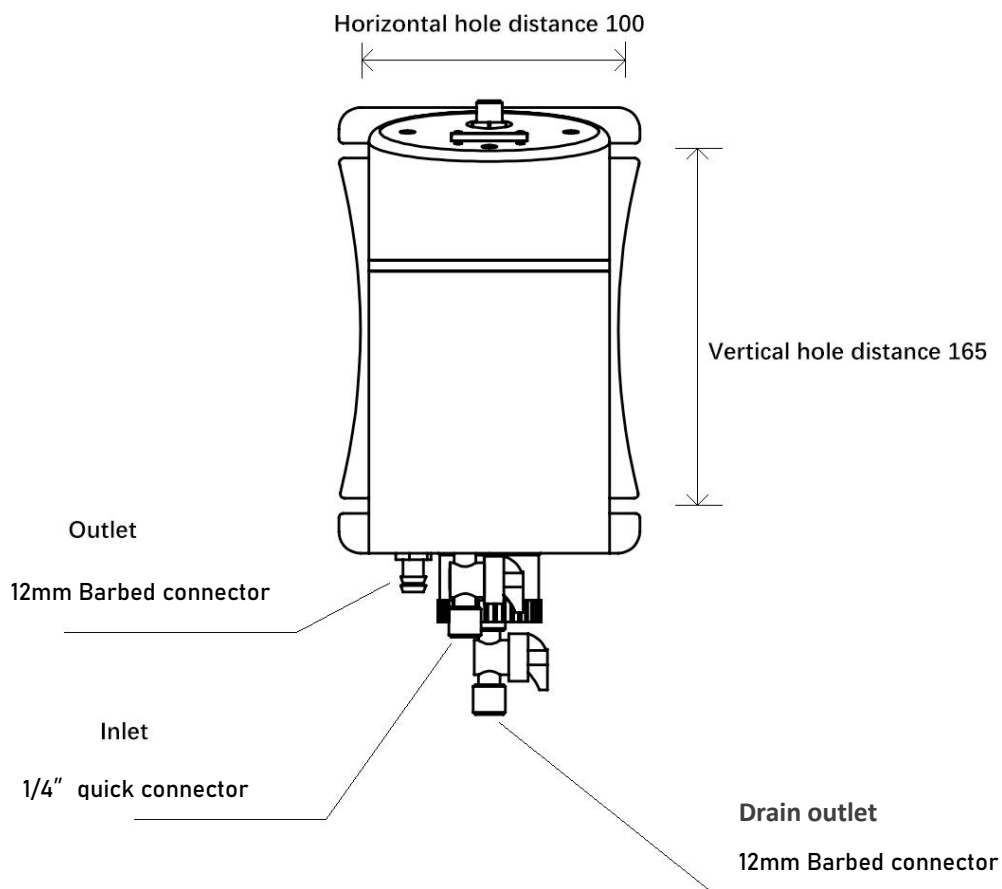

Figure 2 Schematic diagram of installation of flow turbidity sensor

### Sensor installation steps:

- a) Pre-open 4 fixing holes at the required installation position, with a horizontal spacing of 100mm and a vertical spacing of 165mm;
- b) According to the material of the installation location, select appropriate bolts to fix the flow cell to the installation location;
- c) Install the injection pipeline. The injection pipe uses a 1/4" PE tube. Insert the PE tube into the quick connector of the water inlet throttle valve and insert it firmly until the PE tube cannot be inserted further;
- d) Install the drain pipe, the drain pipe is a 12mm silicone tube, and the drain pipe is connected to the sensor drain port barb fitting;
- e) Check and close the drain valve, slowly open the throttle valve at the water inlet, and observe whether there is sample injection in the flow cell;
- f) Put the sensor into the flow cell, and rotate the sensor to the left and right slightly to make sure it is just in place on the flow cell. If the sensor is not properly seated, it will cause light leakage and false readings.



**Note: Ensure the level of the turbidity sensor body when installing.**

The sensor injection flow rate is required to be between 100 and 700 ml/min. The flow into the turbidity sensor can be controlled by a shutoff valve on the water inlet. Flow rates below 100 ml/min will reduce response time and cause incorrect readings. Flow rates higher than 700 ml/min will cause the turbidity sensor to overflow.

### 3.2 Sensor Wiring

The sensor is connected to the meter or data acquisition device as defined in the table below.

Wire color	White	Blue	Grey	Black
Terminal definition	+12VDC	AGND	RS485 data A (+)	RS485 data B (-)
Instrument terminal symbol	V+	V-	AS	BS

## Part 3 The use of the sensor connected to the instrument

### Chapter 4

#### System default setting value

Instrument display range: 0 ~ 100NTU

Menu item	Submenu item		Default setting
<b>Probe set</b>	Zero cal		1NTU
	Slope cal		20NTU
	Sample cal		20NTU
<b>Alarm set</b>	Relay 1	Function set	Main measurement control
		On value	100NTU
		Off value	99.5NTU
	Relay 2	Function set	Main measurement control
		On value	0NTU
		Off value	0.5NTU
<b>Current set</b>	Current 1	Output type	4-20mA
		Channel selection	Main measurement control
		Upper limit	100NTU
		lower limit	0NTU
	Current 2	Output type	4-20mA
		Channel selection	Temperature channel
		Upper limit	60℃
		lower limit	0℃

# Chapter 5

## Probe set

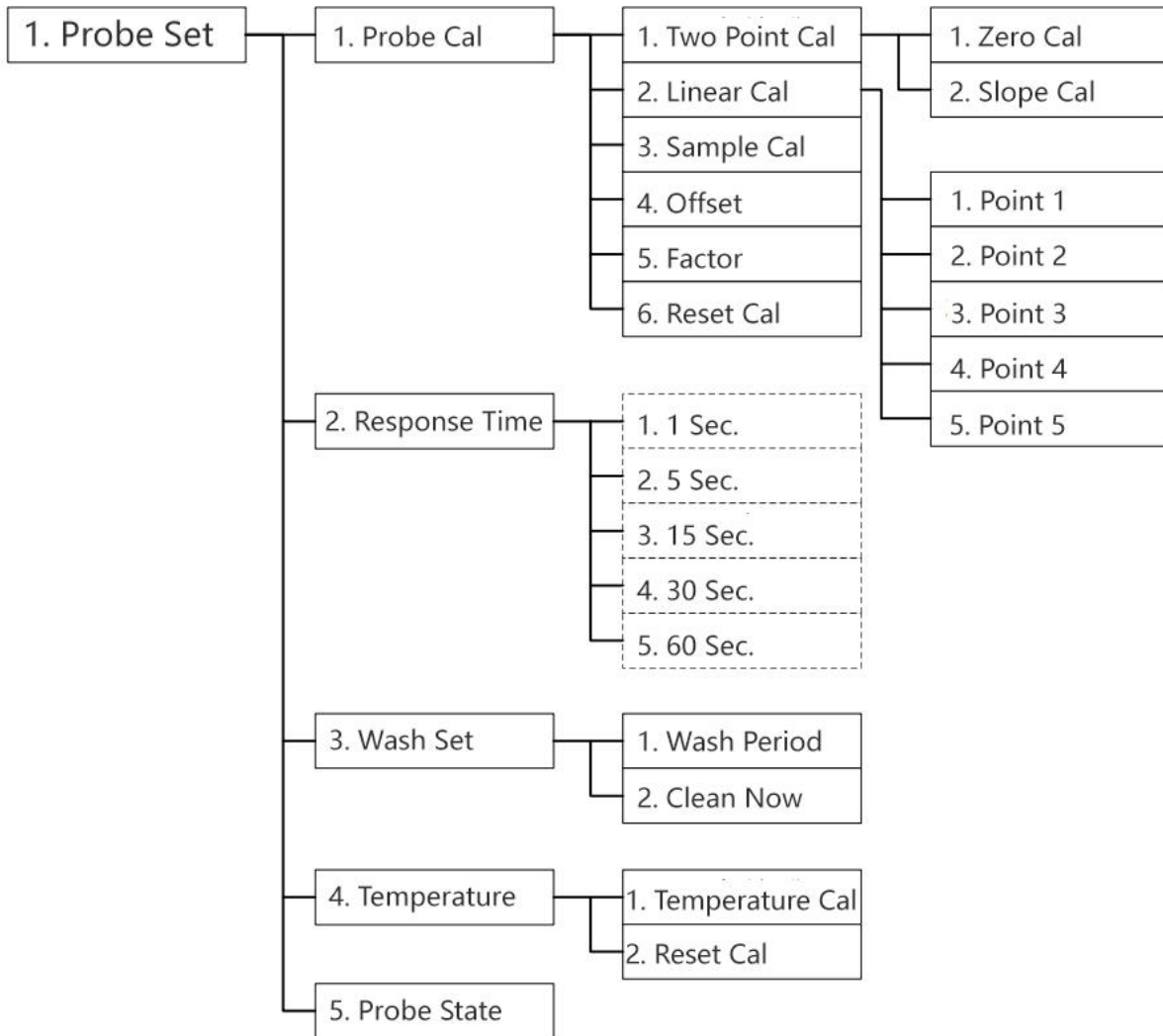

When the instrument is in the measuring state, long press the key  to enter the main menu. The following is a schematic diagram of the menu structure of the electrode setting section:



## 6.1 Probe Cal

### Two-point cal

Two-point calibration needs to prepare two water samples with known turbidity values, and calibrate according to the following steps:

- a) Clean the transmitter and receiver windows and sensor body with deionized water before calibration, and dry them with a soft, lint-free cloth;
- b) In the menu, set "offset" to 0, and "factor" to 1;
- c) Connect the low-concentration water sample to the sensor, circulate the water sample, and wait for the sensor reading to stabilize;
- d) Select "Zero calibration" in the menu, enter the turbidity value of the water sample, press the key  to start the calibration, and wait for the end of the calibration;
- e) Clean the sensor and wipe dry;
- f) Connect the high-concentration water sample to the sensor, circulate the water sample, and wait for the sensor reading to stabilize;
- g) Select "Slope Cal" in the menu, enter the turbidity value of the water sample, press the key  to start the calibration, and wait for the end of the calibration.

### Linear calibration

Two-point calibration is usually sufficient, to obtain higher accuracy, you can use multi-point calibration. The sensor provides up to 5 calibration points for linear calibration. The linear calibration steps are the same as the two-point calibration. You can select 1~5 points calibration according to actual needs.



**Note:** When performing calibration, the order of turbidity value from low to high is required, point-by-point calibration, and the middle calibration point cannot be skipped.

### Sample cal

After the sensor is installed on site, the meter provides on-site comparison and calibration function, the calibration steps are as follows:

- a) Wait for the sensor reading to stabilize, take out the water sample from the sampling port, and use the calibrated turbidity meter to analyze the turbidity value of the water sample;
- b) Select "Sample Cal" in the menu, enter the turbidity value of the water sample, press the key  to start the calibration, and wait for the end of the calibration.

### Offset correction

This menu can view or modify the sensor offset value.

### Factor correction

This menu can view or modify the sensor factor value.

The relationship between deviation and factor correction is as follows:

***Sensor reading = (turbidity + offset value) \* factor value***

### Reset cal

Select confirm, press the key  then "Please Wait..." will appear, and the sensor turbidity calibration parameters will be restored to the factory state. After the restoration is completed, the system will automatically return to the previous menu.

## 6.2 Response Time

Set the sensor measurement response time. Setting a longer response time can eliminate the fluctuation of the measured value caused by unstable factors such as bubbles, but it will also reduce the response speed of the sensor. Please set a suitable response time according to actual needs.

## 6.3 Wash Set

Wash period

Set the interval for automatic emptying of the sensor.

Manual clean

Perform an emptying of the flow cell manually.



**Note:** This function is only available for sensors installed with automatic drain outlet system.

## 6.4 Temperature

Temperature cal

Enter the target temperature value in this menu to calibrate the sensor temperature measurement to the entered value.

Reset cal

This menu can restore the temperature calibration parameters.

## 6.5 Probe State

View the current working status of connected sensors:

OK	sensor is working properly
ERROR 1	sensor is out of range
ERROR 2	sensor communication failure

## Part 4 The use of the sensor connected to data acquisition

### Chapter 7

#### Sensor use

##### 7.1 Protocol

Sensor communication is RS485 Modbus-RTU. For specific communication protocol, please refer to the description of Modbus related protocol. The default communication parameters of the sensor are: communication address=1, baud rate=9600, parity bit=none, stop bit=1 bit, the communication parameters can be modified by referring to the register description in Appendix B.

##### 7.2 Reading

The measured value of the sensor can be read by connecting the meter or using other Modbus master station equipment. Please refer to Appendix A for the Modbus register address. The sensor measured value data is 4-byte floating point data, and the data sequence is little-endian-byte exchange. Pay attention to the conversion sequence. For example, read the turbidity measurement value and temperature measurement value, the host sends:

[01 04 00 02 00 04 50 09]

Where 01 is the sensor address; 04 is the function code; 00 02 means the starting address of the register to be read; 00 04 means reading the four registers; 50 09 is the CRC check code

The sensor returns:

[01 04 08 EB 85 3F 81 CC CD 41 C8 19 46]

Among them, 01 address; 04 is the function code; 08 means the return data length is 8 bytes; EB 85 3F 81 means the turbidity 1.015NTU; CC CD 41 C8 means the temperature is 25.1°C; 19 46 means the CRC check.

##### 7.3 Calibration

###### Two-point calibration

The turbidity sensor has been calibrated before leaving the factory. If you need to calibrate yourself, you can follow the steps below. Two-point calibration can calibrate the sensor through two standard solutions/water samples. For two-point calibration, you need to test low-concentration water samples first, and then test high-concentration water samples. Specific steps are as follows:

- a) Clean the transmitter and receiver windows and sensor body with deionized water before calibration, and dry them with a soft, lint-free cloth;
- b) Set the sensor offset value to 0 and the factor value to 1;
- c) Connect a low-concentration water sample with a turbidity value of T1, circulate the water sample, and wait for the sensor reading to stabilize and record the turbidity value R1;
- d) Clean the sensor and wipe dry;
- e) Connect a high-concentration water sample with a turbidity value of T2, circulate the water sample, and wait for the sensor reading to stabilize and record the turbidity value R2;
- f) Calculate the offset value C and the factor value K, and write them into the sensor.

$$K=(T2-T1)/(R2-R1)$$

$$C=T2/K-R2$$

### Linear calibration

Two-point calibration is usually sufficient. To obtain higher accuracy, multi-point calibration can be used. The sensor provides up to 5 calibration points for linear calibration.

- a) For multi-point calibration, connect the first point of water sample to the sensor, circulate the water sample and wait for the sensor to stabilize;
- b) Use the 16 function code to write the turbidity value of the water sample to the No. 17 register;
- c) Clean the sensor, connect the second water sample to the sensor, cycle and wait for the sensor reading to stabilize;
- d) Use the 16 function code to write the turbidity value of the water sample to the 19th register;
- e) Repeat the above steps until the required points are calibrated.



**Note:** The water sample value used for the calibration points can be selected arbitrarily. It is recommended to select the calibration points uniformly within the actual measurement range.

When calibrating, the order of the turbidity value from low to high is required, point-by-point calibration, and the middle calibration point cannot be skipped. 1~5 points can be calibrated according to actual needs.

The effects of "offset" and "factor" will be superimposed on the "linear calibration". Before using "linear calibration", perform "reset calibration" on the sensor or manually set the offset value to 0 and the factor value to 1, linear After calibration, you can use "offset" and "factor" to adjust the zero point and slope of the sensor

It is not possible to write 0 in the linear calibration point.

### 7.4 Reset CAL

Use the function code 06 to write a value of 10 to the No. 10 register to restore the sensor calibration parameters to the factory state.

### 7.5 Temp CAL

The sensor provides temperature offset value parameters to calibrate temperature. The relationship between temperature measurement value and temperature deviation is as follows:

Temperature reading = temperature measurement value + temperature offset value

When calibrating the temperature, the temperature offset value can be calculated according to the actual temperature value that needs to be calibrated, and it can be written into the corresponding register.



## Part 5 Maintenance

### Chapter 8

#### Maintenance

The sensor contains precision photoelectric components. Please make sure that the sensor will not be subject to any strong mechanical impact during use. There are no user maintenance parts inside the sensor.

#### 8.1 Maintenance cycle

Maintenance work	Maintenance frequency
Visual inspection	Every month
Check calibration	Every month (According to the environmental conditions)

#### 8.2 Cleaning

Keeping the sensor's measurement window clean is critical for accurate measurement. The measurement window should be checked every month for stains. When maintenance is required, the measuring window can be cleaned with detergent and cloth.

#### 8.3 Drain

When the sensor is used in a heavily polluted environment for a long time, there will be debris deposits at the bottom of the flow cell, and the drain valve can be used to drain the water sample in the flow cell regularly to achieve the effect of drain discharge.



# Appendix

## A Modbus register information

### 1. Modbus RTU Overview:

The instrument acts as a slave on the network and supports the Modbus RTU communication protocol. The data communication is initiated by the host and the first byte of the transmitted message is the target slave address. When the first byte is received by all slaves on the network, each slave will decode it to determine whether the message is sent to itself.

The transmission of the RTU message frame starts with a pause interval of at least 3.5 characters. After the last character is transmitted, a pause of at least 3.5 characters marks the end of the message frame. A new message can start after this pause. In the transmission process, the entire message frame must be transmitted in a continuous stream. If there is a pause of more than 1.5 characters before the completion of the message frame transmission, the receiving device will refresh the incomplete message and assume that the next byte is the start of the new message. Similarly, if a new message starts after the previous message frame in less than 3.5 character, the receiving device will assume that it is a continuation of the previous frame, and this will cause an error because the last CRC value cannot be correct.

The host can send a command frame to read a single or all data results.

### 2. Function code details (function code 0)

This function enables the host (upper computer) to obtain the real-time measured value from the slave (instrument). The value is specified as a single-precision floating-point type (that is, occupying 2 consecutive register addresses), and the corresponding parameter are marked by different register address. The host can send the command frames to read single or all data results. The data frame format is as follows(all data are in Hex format) :

Host send:

1	2	3	4	5	6	7	8
Slave address	Function code	Register start Address high 8 bit	Register start Address low 8 bit	Register number high 8 bit	Register number low 8 bit	CRC low 8 bit	CRC high 8 bit

Slave response:

1	2	3	4	5	5+n	5+n+1	5+n+2	5+n+3
Slave address	Function code	Number of data bytes	Data 1 high 8 bit	Data 1 low 8 bit	Data n high 8 bit	Data n low 8 bit	CRC low 8 bit	CRC high 8 bit



#### Note:

1. Addr is the slave address, and the optional range is 0x01~0xFE;
2. Len is the number of bytes of the returned data.

For example:

Send frame: [01 04 00 02 00 02 D0 0B], the meaning is as follows:

[01]: slave address

[04]: Function code

[00 02]: The starting address of the register is 0x02

[00 02]: Read 2 registers from the starting address (ie read 1 single-precision floating-point data result)

[D0 0B]: CRC check data

Return frame: [01 04 04 00 00 41 C8 CA 42], the meaning is as follows:

[01]: slave address

[04]: Function code

[04]: The number of bytes returned is 4

[00 00 41 C8]: 41 C8 00 00 (that is, the floating-point value is 25, and the meaning of the specific value is to find the corresponding address)

(Note: Combine two 16-bit integer registers to form a single-precision floating-point number, pay attention to the order of data)

### 3. Corresponding parameter table of communication address:

When using the instrument communication function, the corresponding parameter table of the communication address is as follows:

- 00 Turbidity value (NTU)
- 02 Temperature value (°C)
- 06 Current 1 output value (mA)
- 08 Current 2 output value (mA)

# Appendix

## B Modbus register information

Name	Register	Data type	Length	Access type	Function code	Description
State	1	Unsigned integer	1	Read only	04	When the 0th digit is 1, it means that the measurement is over range, when the 1st digit is 1, it means that the measurement has a negative value, and the remaining digits are reserved
Turbidity measurement value	2	floating point	2	Read only	04	Turbidity unit NTU
Temperature measurement value	4	floating point	2	Read only	04	Temperature unit °C
Serial number	8	String	6	Read only	04	Serial number represented by 12-bit ASCII code
Firmware version	14	Unsigned integer	1	Read only	04	version number x100
Address	0	Unsigned integer	1	Read/Write	03/06	Communication address range 1~254, default 1
Baud rate	1	Unsigned integer	1	Read/Write	03/06	0=4800,1=9600 (default) , 2=19200,3=38400
Verify bit	2	Unsigned integer	1	Read/Write	03/06	0=No (default) , 1=Odd, 2=Even
Stop bit	3	Unsigned integer	1	Read/Write	03/06	1=1STOP (default) , 2=1.5STOP, 3=2STOP
Response time	4	Unsigned integer	1	Read/Write	03/06	0=1s,1=5s,2=15s,3=30s,4=60s
Turbidity resolution	5	Unsigned integer	1	Read/Write	03/06	0=Floating point,1=1 decimal,2=2 decimal places,3=3 decimal places
Turbidity offset	6	floating point	2	Read/Write	03/16	The offset value defaults to 0
Turbidity factor	8	floating point	2	Read/Write	03/16	The factor value defaults to 1
Reset calibration	10	Unsigned integer	1	Write only	06	Write 10 to reset turbidity calibration
Temperature offset	11	floating point	2	Read/Write	03/16	Temperature deviation default 0°C
Linear calibration point 1	17	floating point	2	Read/Write	03/16	Write turbidity target value to start calibration
Linear calibration point 2	19	floating point	2	Read/Write	03/16	Write turbidity target value to start calibration
Linear calibration point 3	21	floating point	2	Read/Write	03/16	Write turbidity target value to start calibration
Linear calibration point 4	23	floating point	2	Read/Write	03/16	Write turbidity target value to start calibration
Linear calibration point 5	25	floating point	2	Read/Write	03/16	Write turbidity target value to start calibration







---

**Delfino Environmental Technology Co., Ltd.**  
**[www.daruifuno.com](http://www.daruifuno.com)**  
**[info@daruifuno.com](mailto:info@daruifuno.com)**